

TEST REPORT No. 338859/10299/CPR

issued by Istituto Giordano in the capacity of notified test laboratory (No. 0407)
pursuant to Regulation 305/2011/EU of the European Parliament and of the Council of 9 March 2011

Place and date of issue: Bellaria-Igea Marina - Italy, 29/12/2016

Customer: EXALCO S.A. R&D Dept. - 5th km Old Nat. Road Larisas-Athinas - 41110 LARISA - Greece

Date testing requested: 19/09/2016

Order number and date: 70974, 19/09/2016

Date technical documentation received: 20/09/2016

Date of testing: from 14/12/2016 to 16/12/2016

Purpose of testing: calculation of thermal transmittance of frame constructed from aluminium profiles with thermal break in accordance with standard UNI EN ISO 10077-2:2012/EC 1-2012, with reference to harmonised standard UNI EN 14351-1:2010

Place of testing: Istituto Giordano S.p.A. - Blocco 2 - Via Rossini, 2 - 47814 Bellaria-Igea Marina (RN) - Italy

Technical documentation origin: supplied by Customer

Name of sample*

The frame for which the calculation is performed is called "ALBIO 235 (SLIDE&FIXED)".



(*) according to that stated by the Customer.

LAB N° 0021

Comp. AV
Revis. CB

This test report consists of 17 sheets.

Sheet
1 of 17

Description of sample*

The sample assembly for which the calculation is performed consists of frames having aluminium profiles with polyamide strips of length 3 mm, 13 mm, 15 mm and 25 mm to provide thermal break. The sash nominal thickness is 60 mm.

The glazing thickness is 24 mm.

The calculation was performed on the basis of Customer-supplied drawings.



(*) according to that stated by the Customer.

DRAWINGS OF THE SECTIONS CONSIDERED
SECTION 1

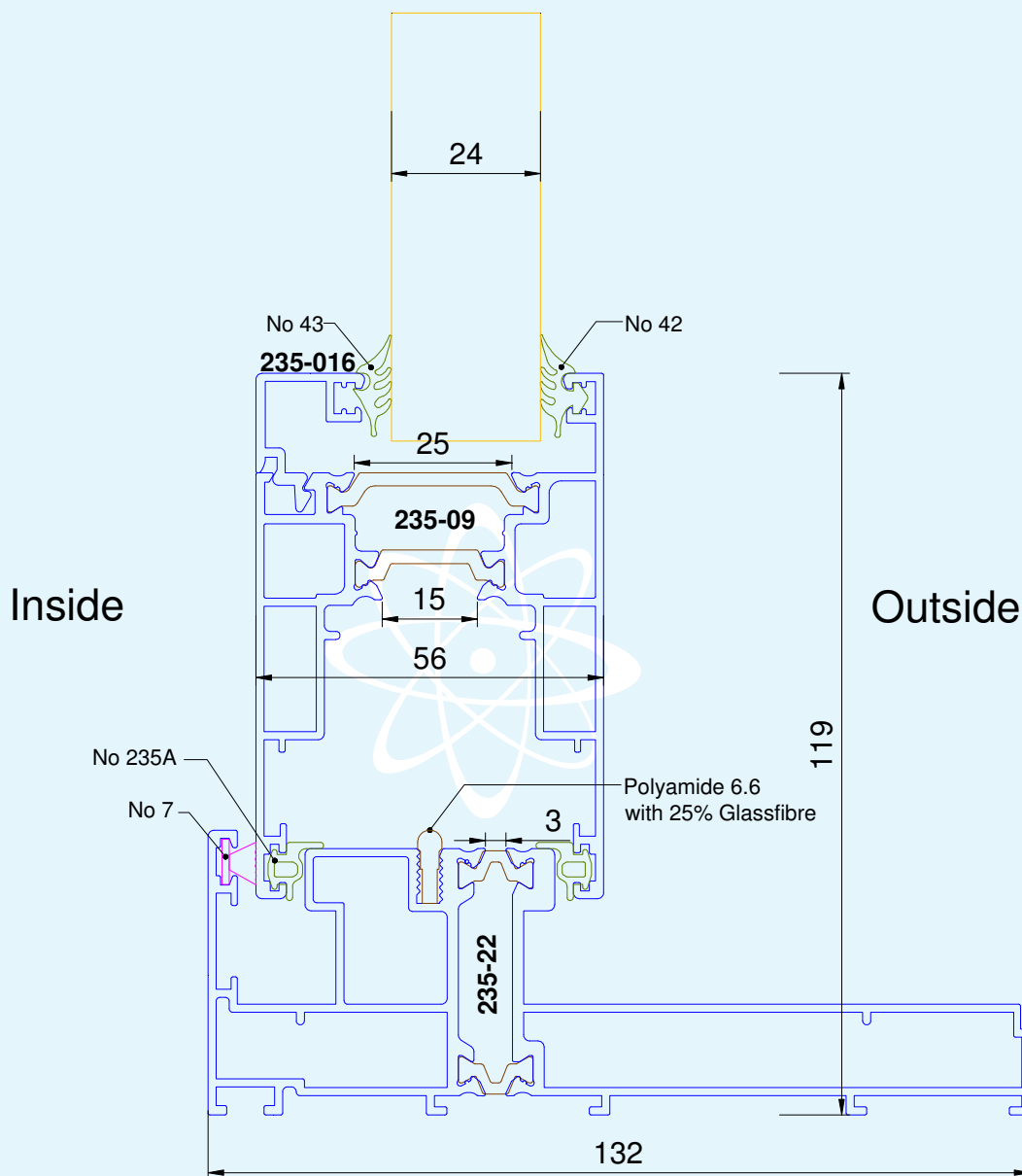

DRAWINGS OF THE SECTIONS CONSIDERED
SECTION 2

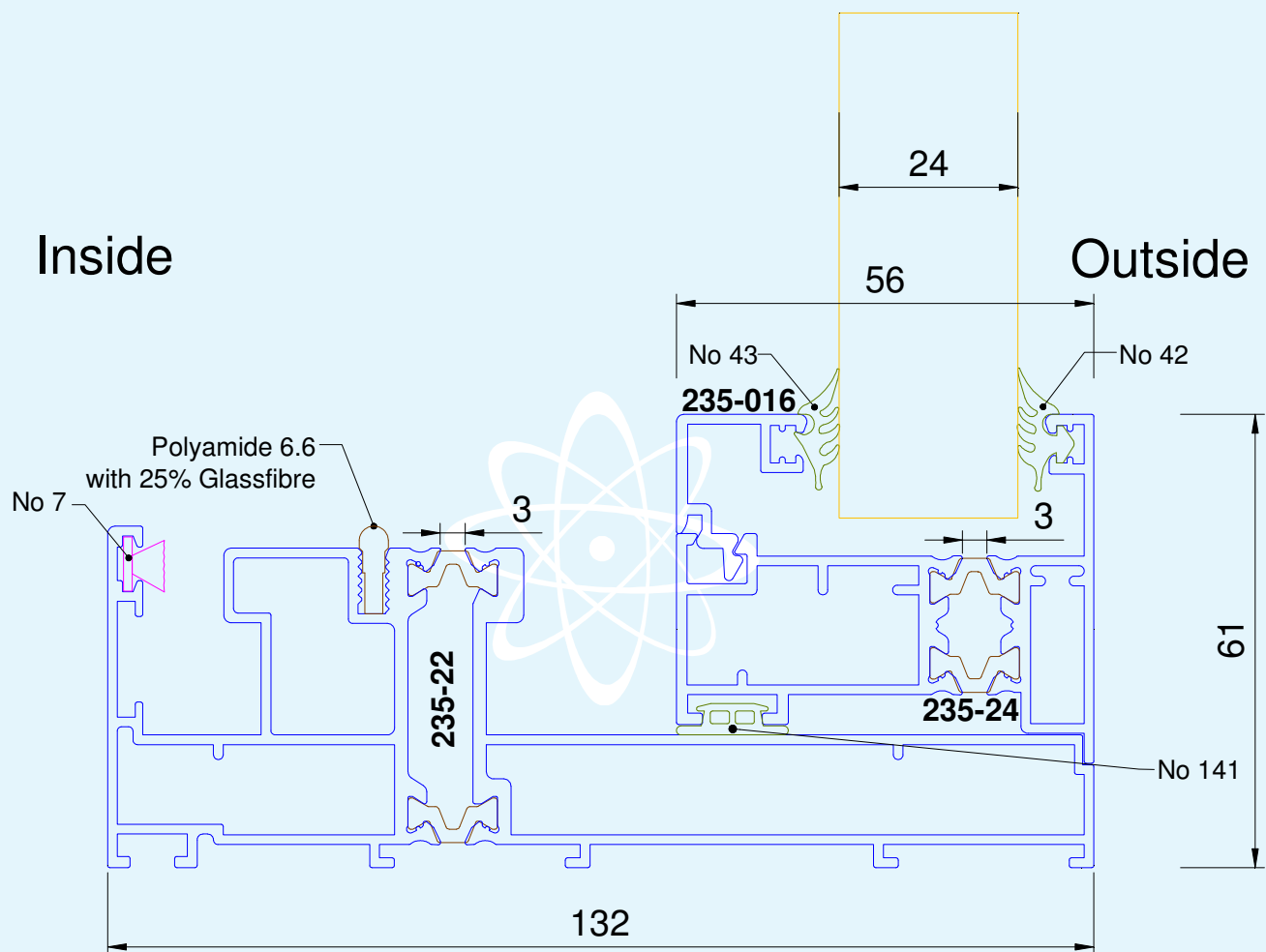

DRAWINGS OF THE SECTIONS CONSIDERED
SECTION 3

Inside

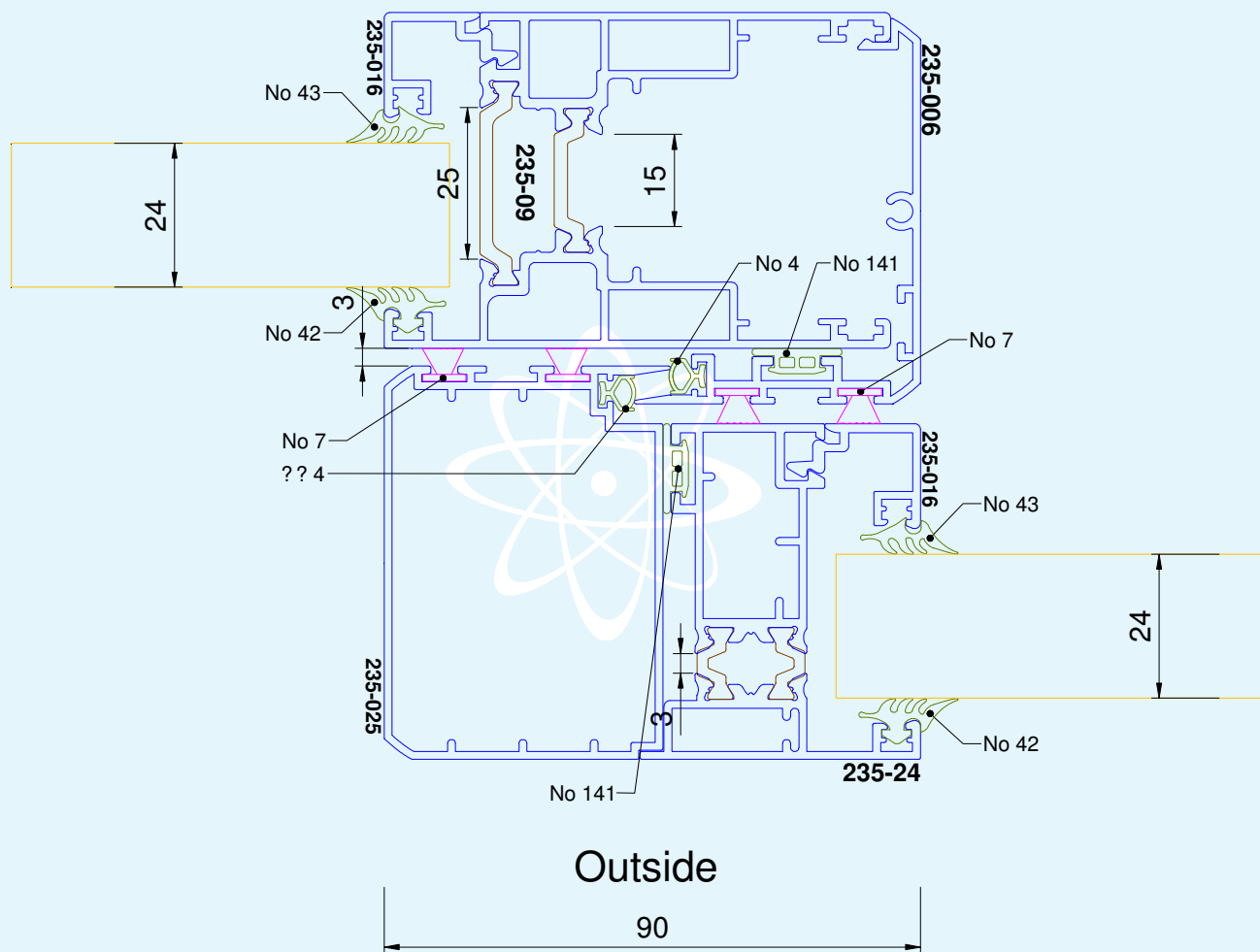

DRAWINGS OF THE SECTIONS CONSIDERED
SECTION 4

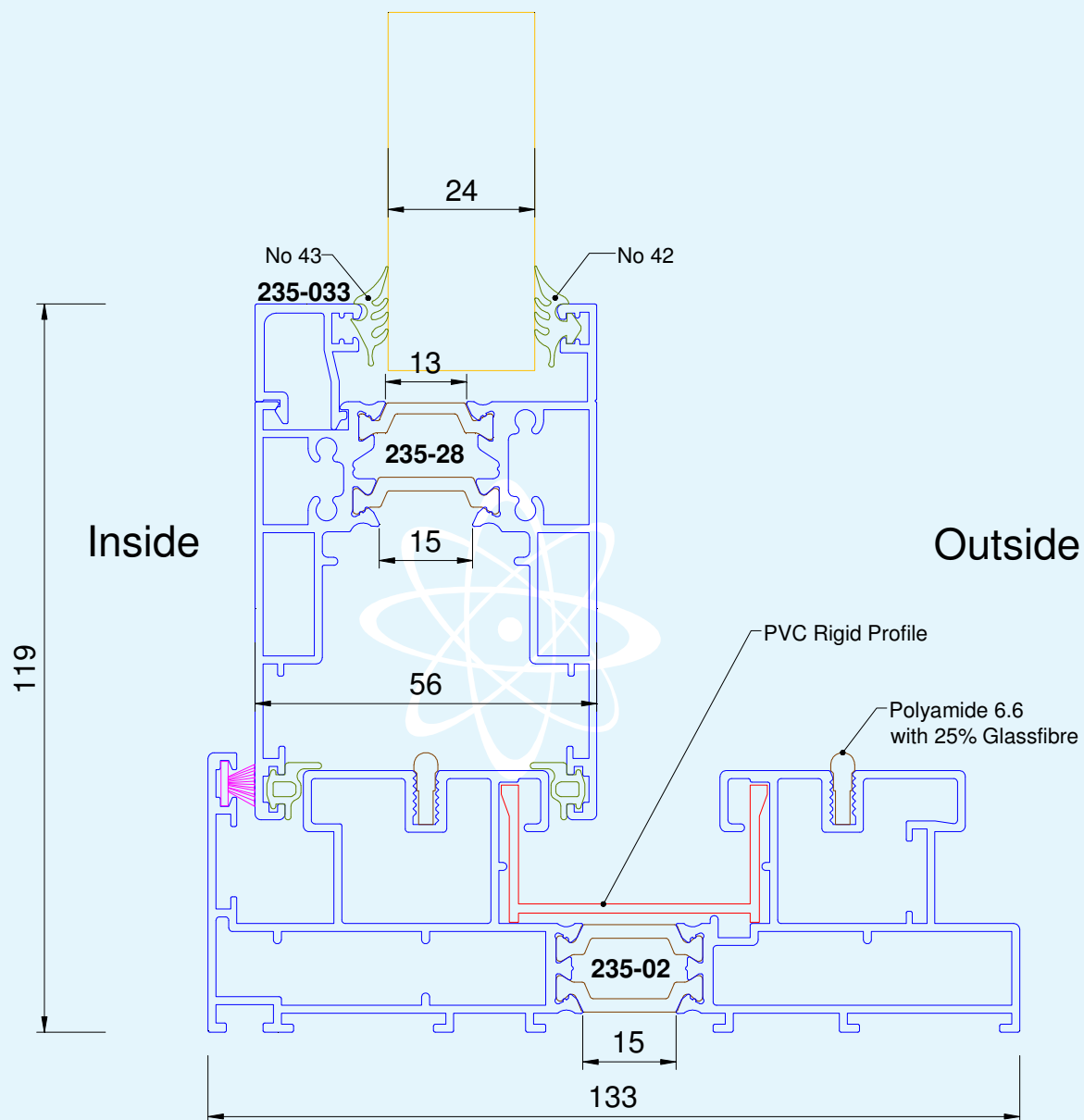

DRAWINGS OF THE SECTIONS CONSIDERED
SECTION 5

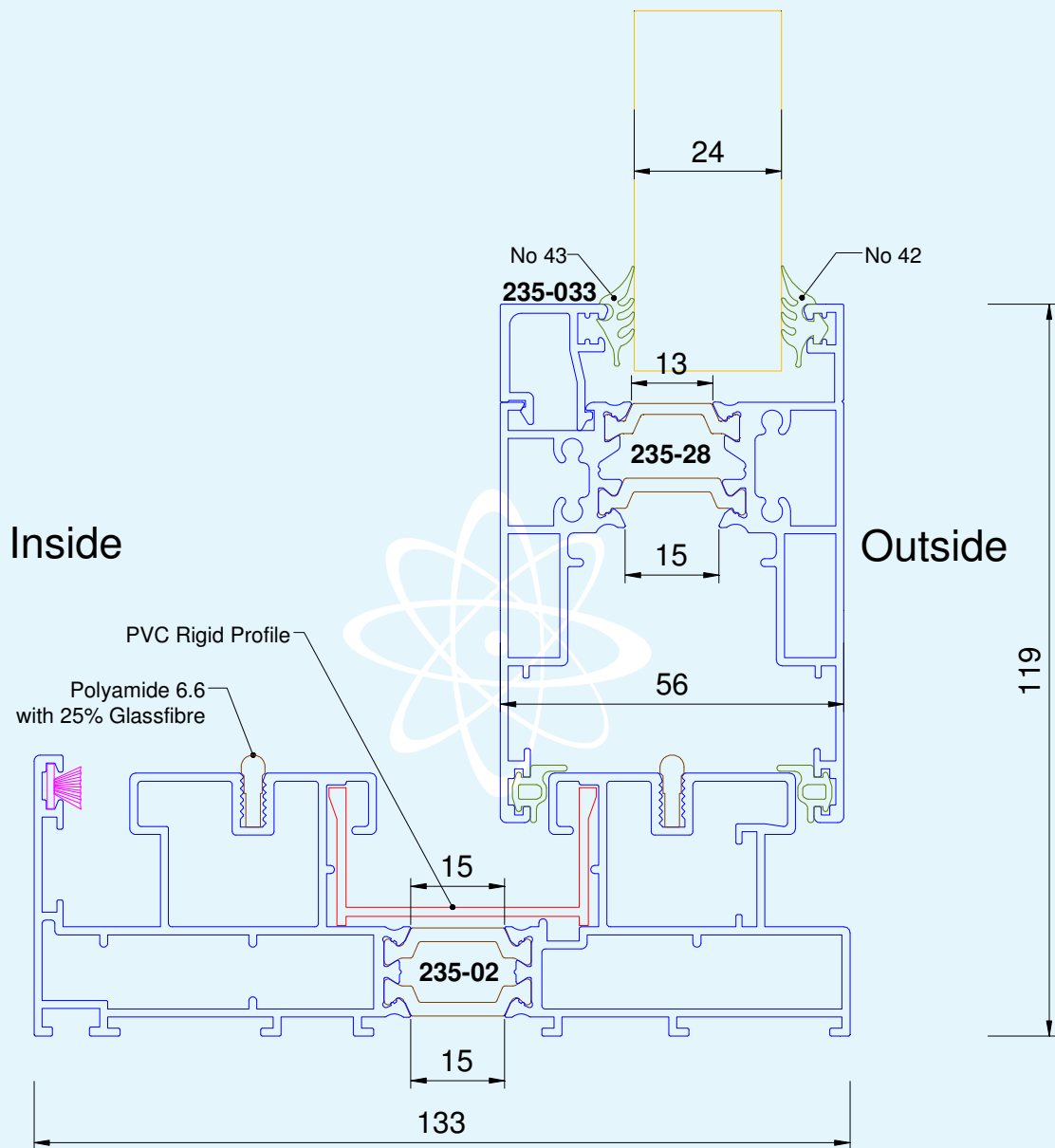

DRAWINGS OF THE SECTIONS CONSIDERED
SECTION 6

Inside

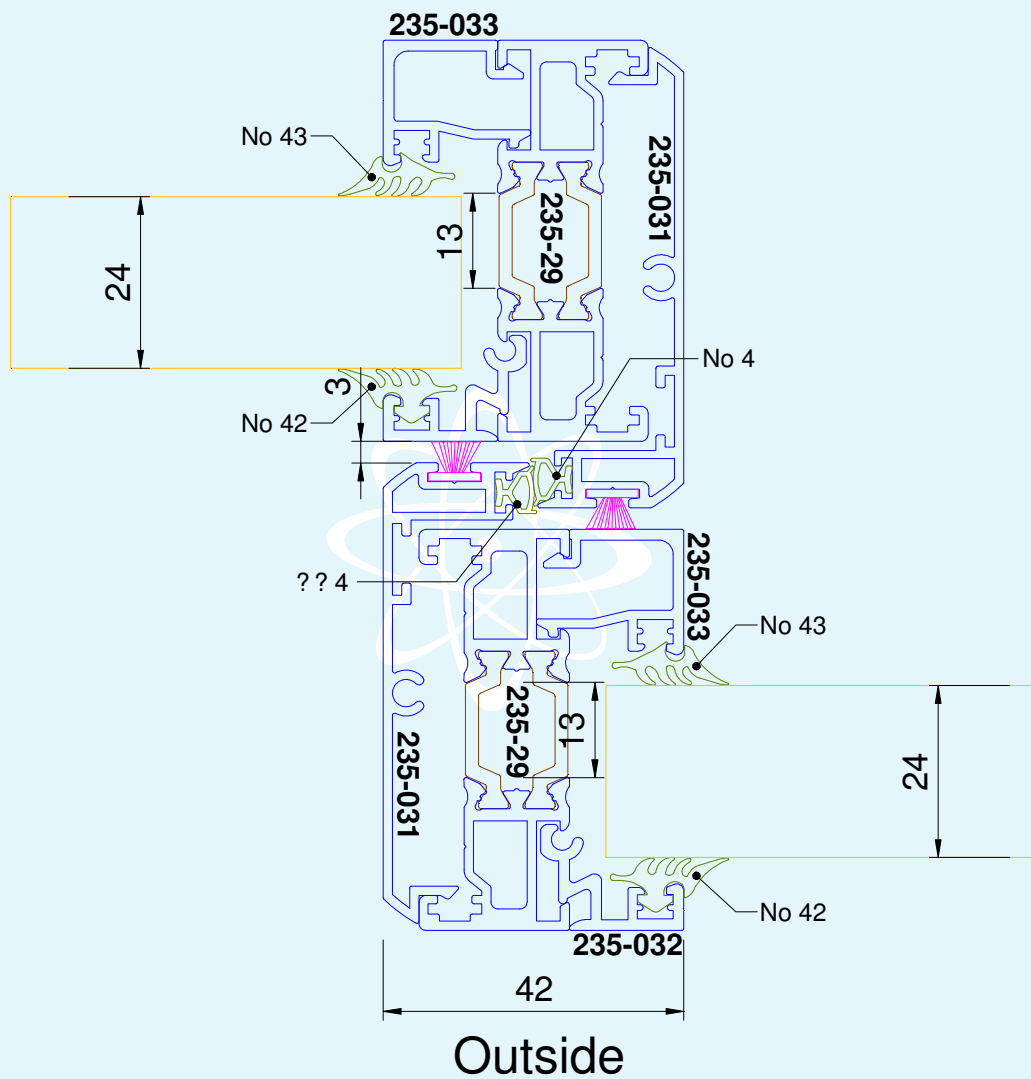

Manufacturing site*

EXALCO S.A. R&D Dept. - 5th km Old Nat. Road Larisas-Athinas - 41110 LARISA - Greece.

Normative references

The test was carried out in accordance with the requirements of the following standards:

- UNI EN ISO 10077-2:2012 dated 12/04/2012 “Prestazione termica di finestre, porte e chiusure - Calcolo della trasmittanza termica - Parte 2: Metodo numerico per i telai” (*“Thermal performance of windows, doors and shutters - Calculation of thermal transmittance - Numerical method for frames”*), with EC 1-2012;
- UNI EN ISO 6946:2008 dated 17/07/2008 “Componenti ed elementi per edilizia - Resistenza termica e trasmittanza termica - Metodo di calcolo” (*“Components and building elements - Thermal resistance and thermal transmittance - Calculation method”*);
- UNI EN 14351-1:2010 dated 15/04/2010 “Finestre e porte - Norma di prodotto, caratteristiche prestazionali. Parte 1: Finestre e porte esterne pedonali senza caratteristiche di resistenza al fuoco e/o di tenuta al fumo” (*“Windows and doors - Product standard, performance characteristics. Part 1: Windows and external pedestrian doorsets without resistance to fire and/or smoke leakage characteristics”*), subclause 4.12 “Trasmittanza termica” (*“Thermal transmittance”*) and Annex E “Determinazione delle caratteristiche” (*“Determination of characteristics”*).

Test method and conditions

The calculation was performed using detailed internal procedure PP072 in its current revision at testing date.

Calculation of frame thermal transmittance

The calculation was performed on the basis of the drawings provided by the Customer, using a numerical finite-element program, complying with standard UNI EN ISO 10077-2, with a maximum discretization size mesh of 0,5 mm, from 49092 to 95595 points. Air spaces were calculated by assigning each one an equivalent thermal conductivity calculated in accordance with the equation specified by standard UNI EN ISO 10077-2.

The frame thermal transmittance value “ U_f ” was calculated by inserting an insulation panel of thermal conductivity $\lambda = 0,035 \text{ W}/(\text{m}^2 \cdot \text{K})$ in place of the infill panel, as specified by Annex C of standard UNI EN (*) according to that stated by the Customer.

ISO 10077-2.

The frame thermal transmittance value “ U_f ”, expressed in $W/(m^2 \cdot K)$, was calculated using the following equation:

$$U_f = \frac{L_f^{2D} - U_p b_p}{b_f}$$

where: L_f^{2D} = thermal conductance of the section, expressed in $W/(m \cdot K)$;

U_p = thermal transmittance of the central area of the panel, expressed in $W/(m^2 \cdot K)$;

b_p = visible width of the panel, expressed in m;

b_f = projected width of the frame section (without protrudine gaskets), expressed in m.

Calculation data

Data for determining frame and linear thermal transmittance

		Value	Data source
Temperature	External temperature	0 °C	UNI EN ISO 10077-2, clause 5.3
	Internal temperature	20 °C	
Surface thermal resistance	External surface thermal resistance “ R_{se} ”	0,04 $m^2 \cdot K/W$	UNI EN ISO 10077-2, table B.1
	Internal surface thermal resistance for surfaces with standard view factor “ R_{si} ”	0,13 $m^2 \cdot K/W$	
	Internal surface thermal resistance for surfaces with reduced view factor	0,20 $m^2 \cdot K/W$	
Characteristics of the frame used for the calculation of the parameter “U_f”	Emissivity of all the materials except aluminium between the thermal break bars	0,9	UNI EN ISO 10077-2, table A.4
	Thermal conductivity of aluminium	160 $W/(m \cdot K)$	UNI EN ISO 10077-2, table A.1, A.2
	Thermal conductivity of EPDM	0,25 $W/(m \cdot K)$	
	Thermal conductivity of polyester mohair	0,14 $W/(m \cdot K)$	
	Thermal conductivity of polyamide reinf.	0,30 $W/(m \cdot K)$	

Test results

Frame thermal transmittance values calculated in accordance with standard UNI EN ISO 10077-2, including fixed and moveable parts (with reference to the widths given in the table), are:

Section	Width considered "b _f " [mm]	Thermal transmittance "U _f " [W/(m ² · K)]
1	119	4,11
2	7561	9,05
3	90	6,54
4	119	4,49
5	119	4,59
6	42	9,74

Note: thermal transmittance values given in the table above have been calculated with glazing thickness 24 mm and therefore are applicable with double glazing.

ISOTHERMS AND FLOW LINES
FOR THE SECTIONS CONSIDERED
SECTION 1

LAB N° 0021

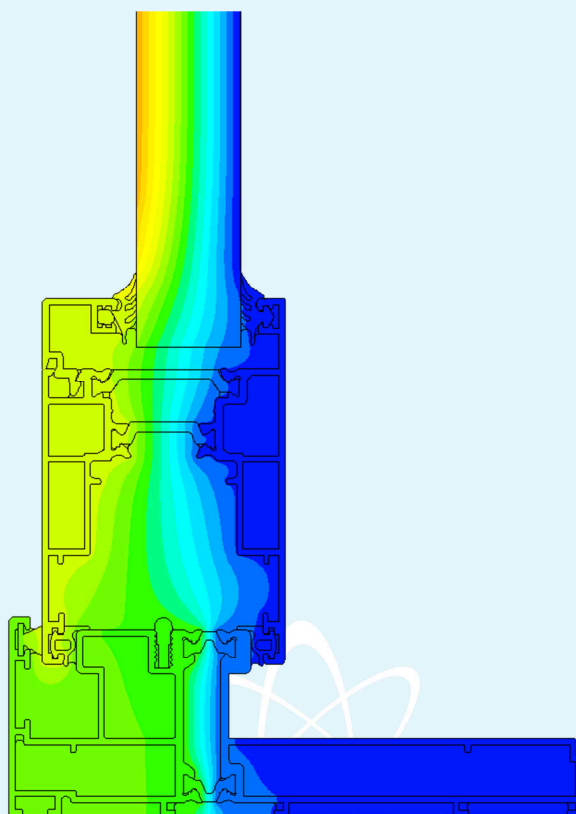

[°C]

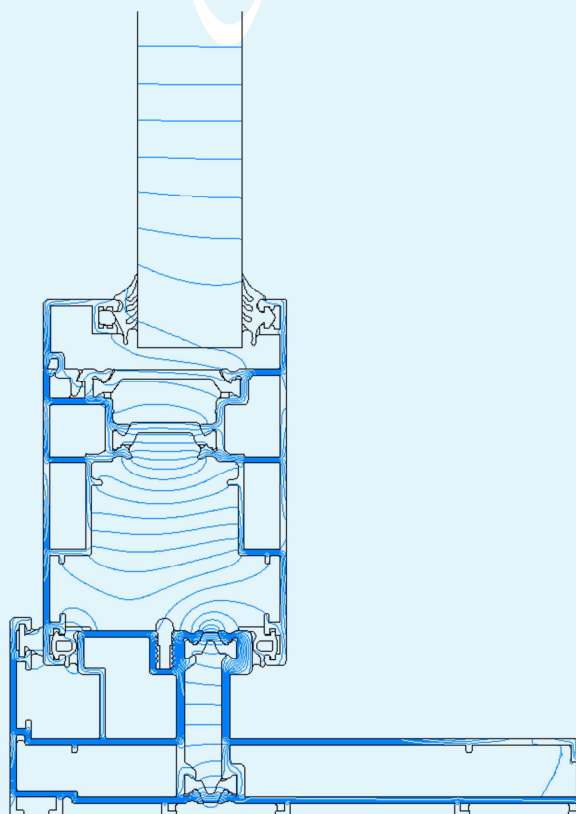
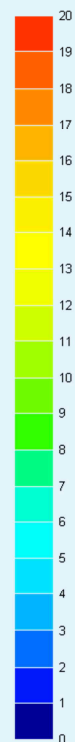

ISOTHERMS AND FLOW LINES
FOR THE SECTIONS CONSIDERED
SECTION 2

LAB N° 0021

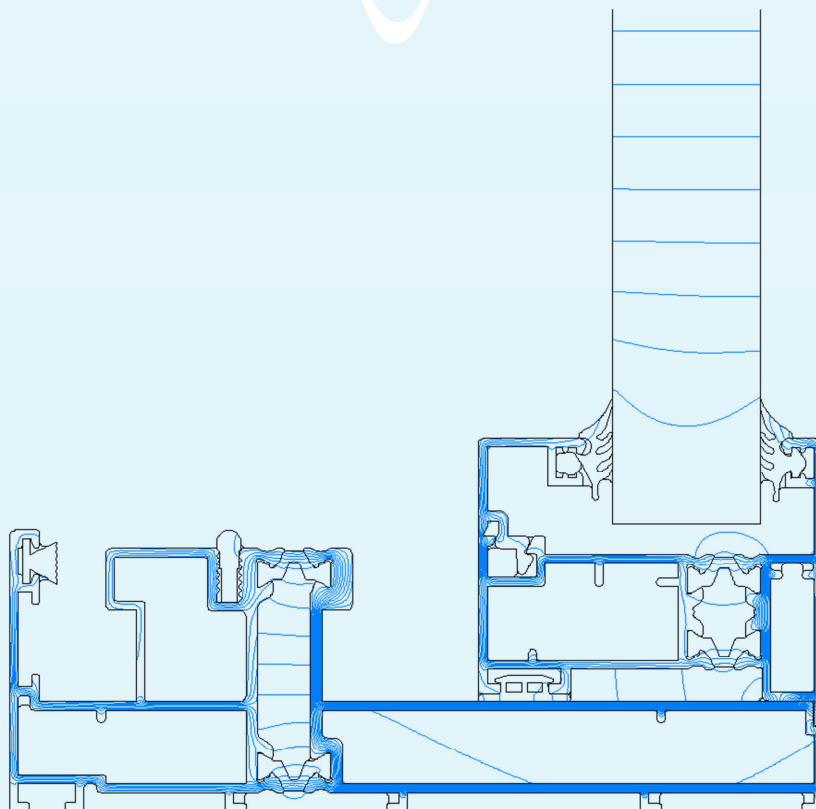
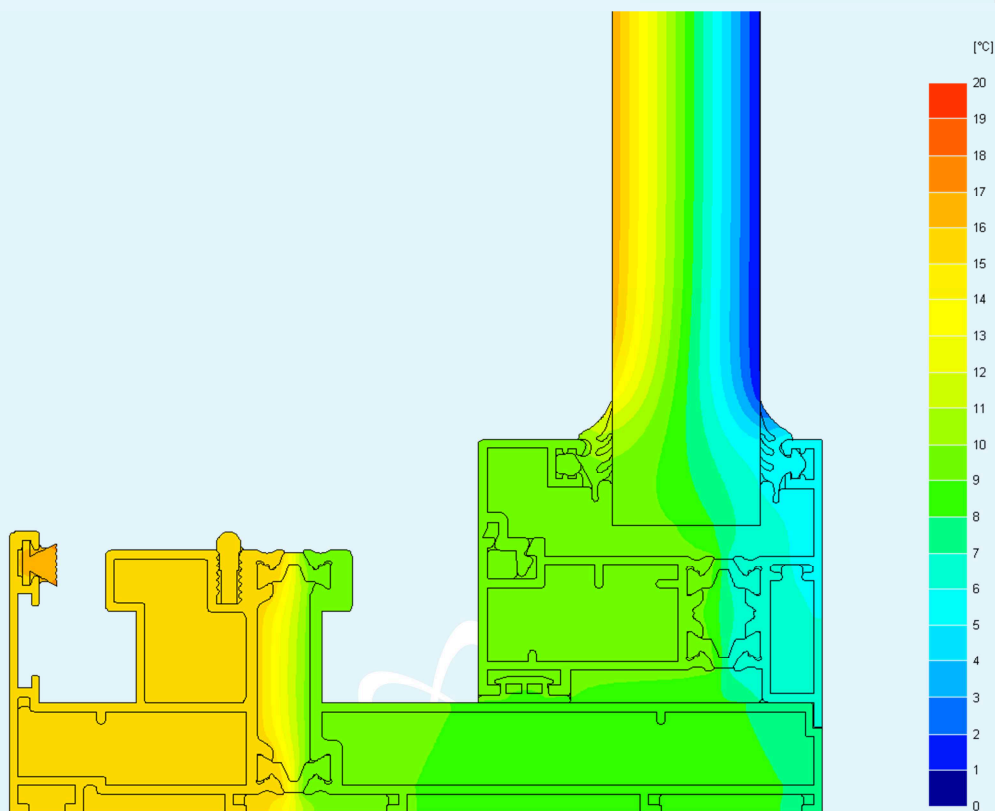

ISOTHERMS AND FLOW LINES
FOR THE SECTIONS CONSIDERED
SECTION 3

LAB N° 0021

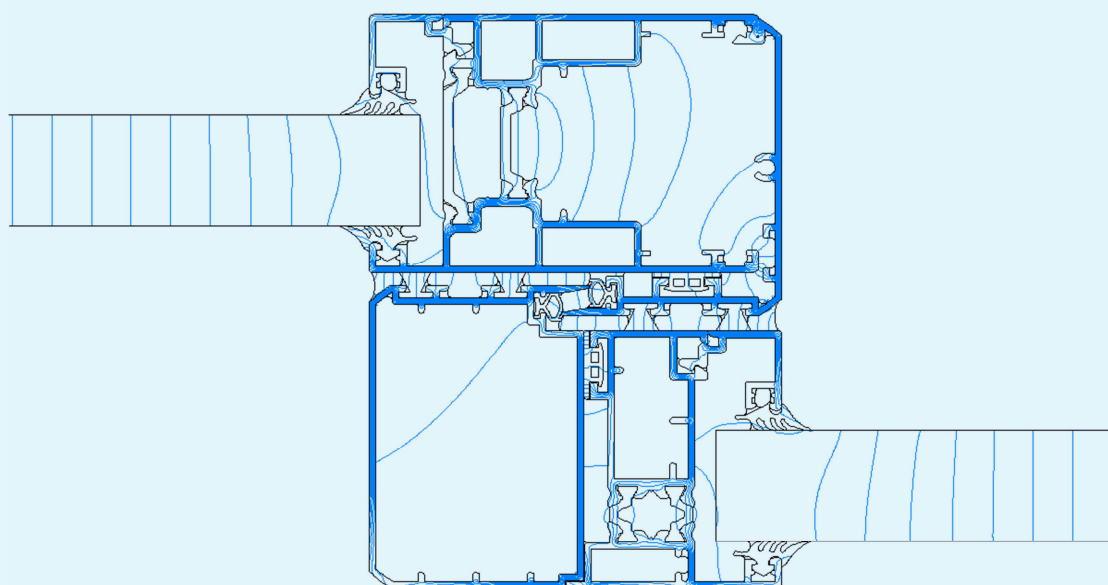
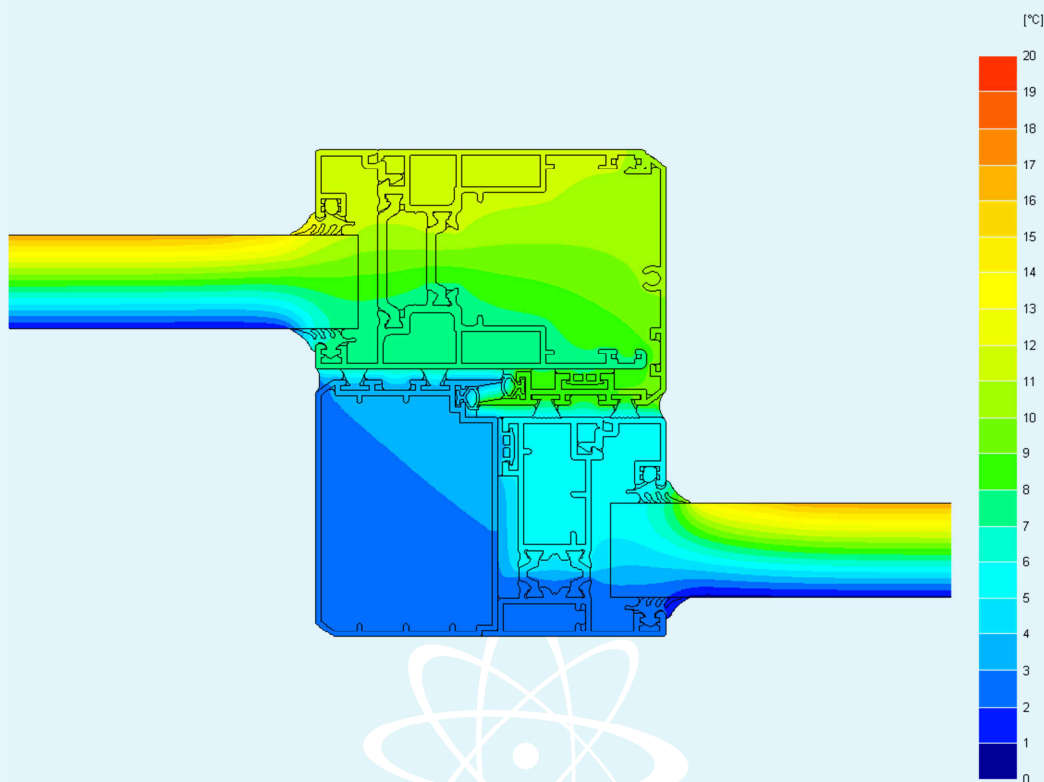

ISOTHERMS AND FLOW LINES
FOR THE SECTIONS CONSIDERED
SECTION 4

LAB N° 0021

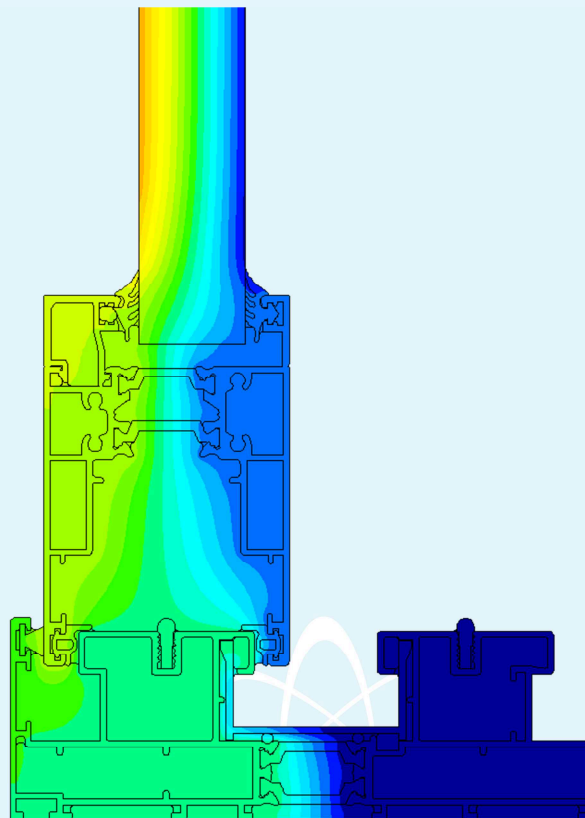

[°C]

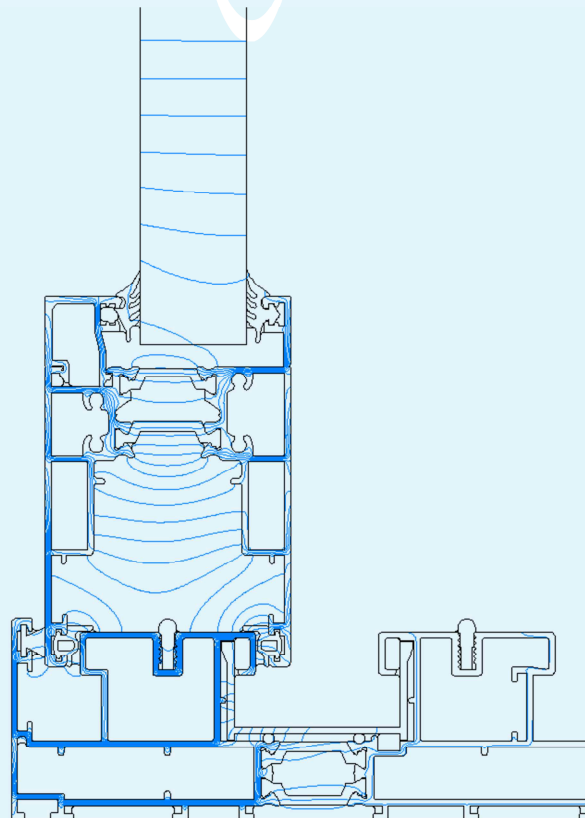
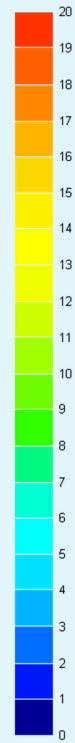

ISOTHERMS AND FLOW LINES
FOR THE SECTIONS CONSIDERED
SECTION 5

LAB N° 0021

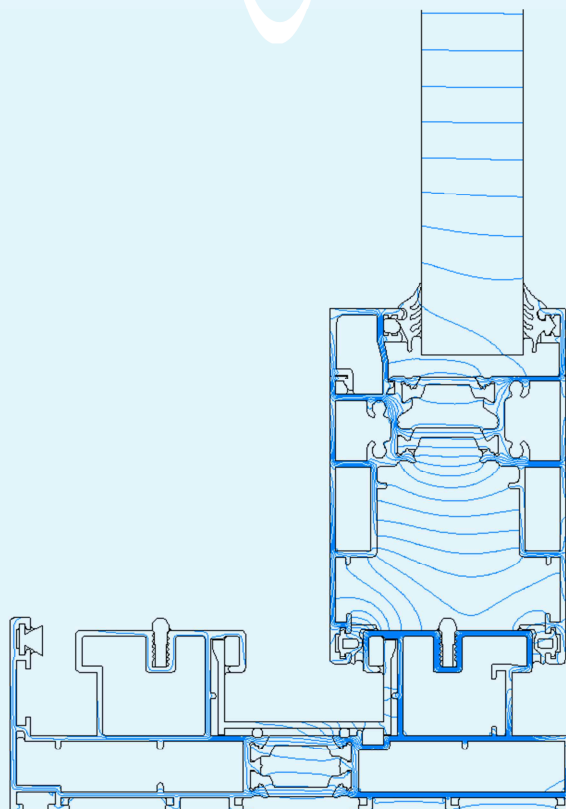
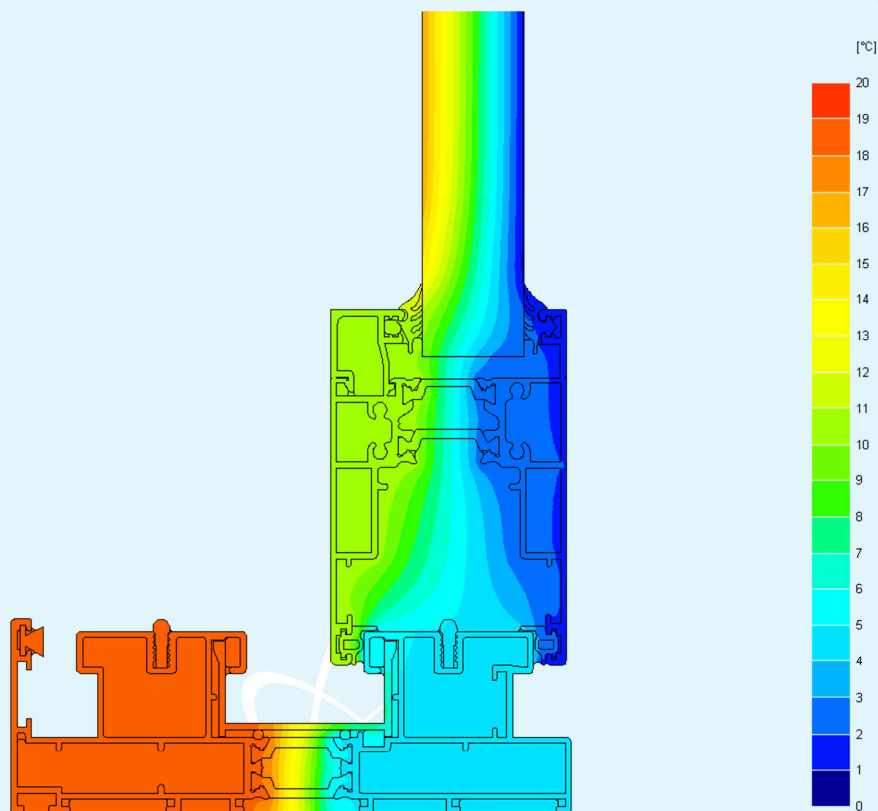

ISOTHERMS AND FLOW LINES
FOR THE SECTIONS CONSIDERED
SECTION 6

LAB N° 0021

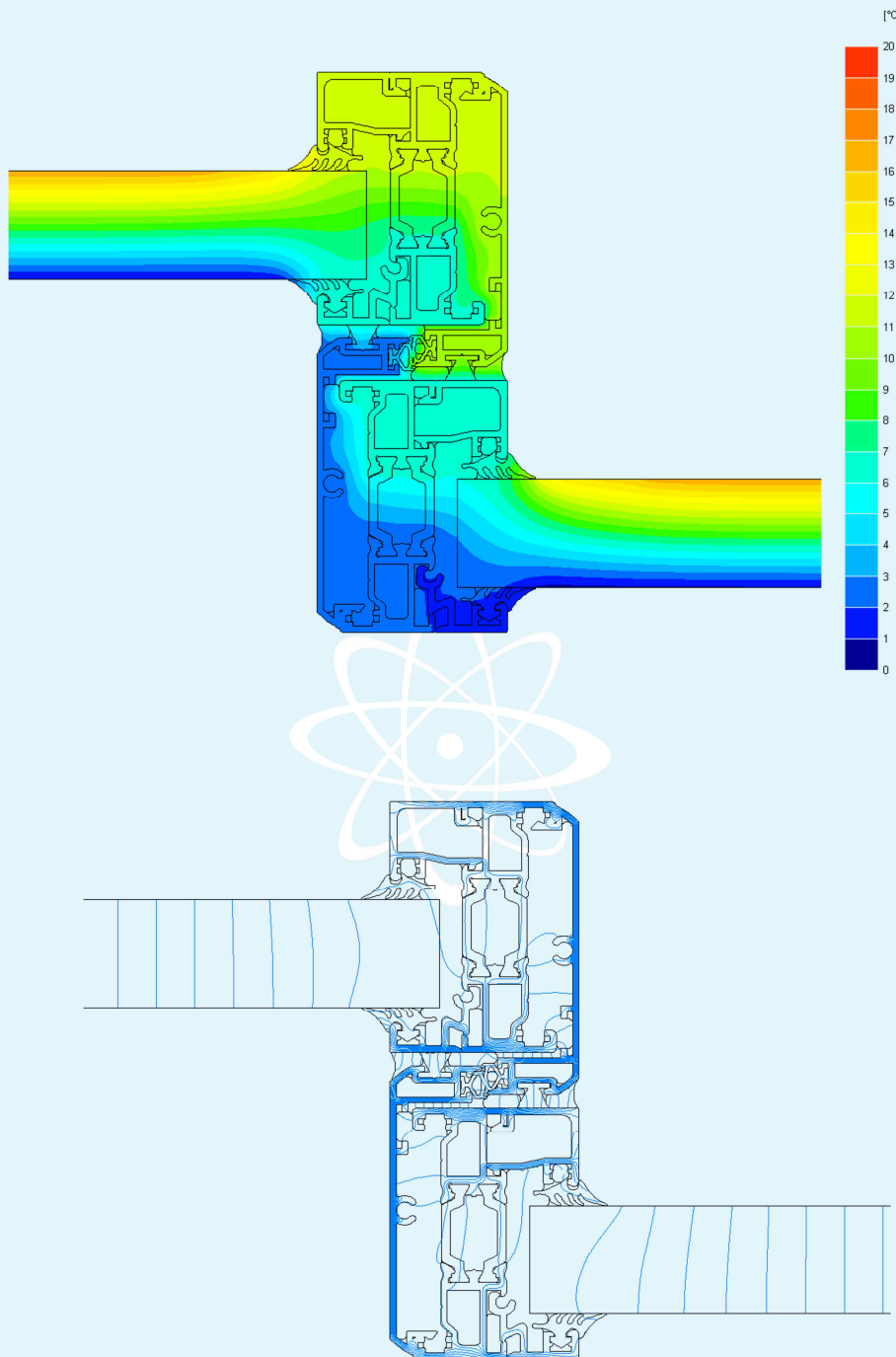

CPD Department
Technical Manager
(Dott. Ing. Giuseppe Persano Adorno)

Test Technician
(Ing. Chiara Bastoni)

Head of Heat Transfer
Laboratory
(Dott. Floriano Tamanti)

Chief Executive Officer
(Dott. Arch. Sara Lorenza Giordano)